

Super Pump® Pro



PROVEN RELIABILITY, ESPECIALLY IMAGINED FOR PROFESSIONALS

- **Heavy duty, high performance** new motor, even more reliable and durable
- Extended-life Viton® and pure graphite pump seal for improved **resistance against chemicals and accidental dry running**
- **Easy maintenance:** exclusive swing-away hand knobs - no tools required
- Direct replacement of former Super Pump® without any installation modification
- Recommended for pools **up to 120 m³***

* Calculation based on 6 hours turnover



Union kit included
2" / 50 mm (1/2-1HP)
2" / 63 mm (1.5-2HP)



See-through strainer cover



Threaded adaptor

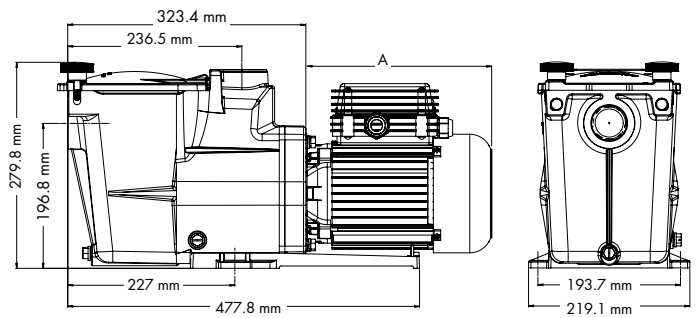

Technical Specifications

Max. water temp.	35°C
Adapter	2" / 50 mm (1/2-1HP) - 2" 63 mm (1.5 -2HP)
Mechanical seal	AISI 304 Viton®, compatible with salt treatment (salt chlorinator)
Motor specifications	Class F, IP55, 50 Hz, 2 Poles
Housing/impeller/strainer/lid	PP+GF/Noryl® + GF/ABS/PC
Prefilter size	1.75 L

THIS PUMP MODEL EXISTS IN VARIABLE SPEED

• Unions 50 mm

Pressure (mbar)

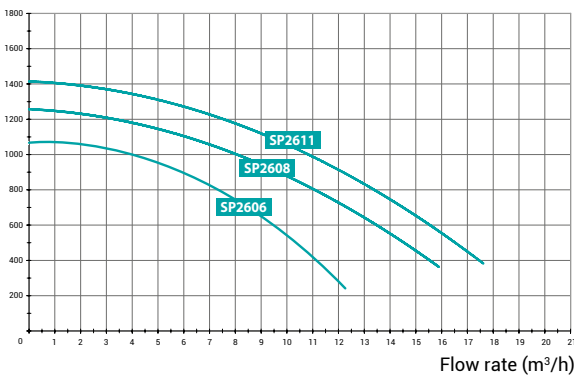

• Unions 63 mm

Pressure (mbar)

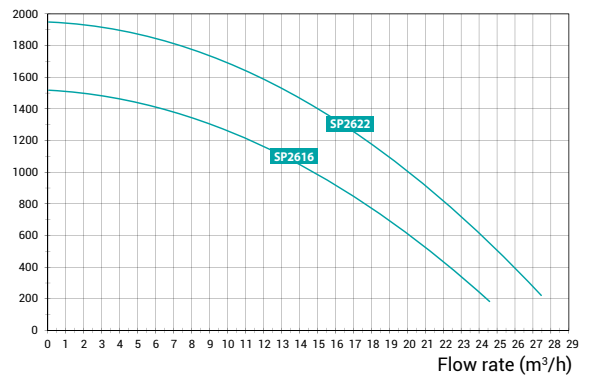

SINGLE PHASE SUPER PUMP® PRO

Type	Dim. A	Weight	Flow rate*	I/O	Fittings	Input Power P1	Output Power P2	Amperage	Quantity per pallet	Item
1/2 HP	213 mm	14.5 kg	8.9 m ³ /h	2" and 1.5"	2": 50 mm	620 W	550 W	3.1 A	24	SP2606HY81
3/4 HP	213 mm	14.5 kg	11.5 m ³ /h	2" and 1.5"	2": 50 mm	730 W	550 W	3.55 A	24	SP2608HY111
1 HP	213 mm	15 kg	13.5 m ³ /h	2" and 1.5"	2": 50 mm	880 W	760 W	4.6 A	24	SP2611HY161
1.5 HP	213 mm	15 kg	17.5 m ³ /h	2"	2": 63 mm	1080 W	790 W	4.95 A	24	SP2616HY221
2 HP	254 mm	18.5 kg	22 m ³ /h	2"	2": 63 mm	1520 W	1200 W	6.8 A	20	SP2622HY251

THREE PHASE SUPER PUMP® PRO

1 HP	254 mm	15.5 kg	13.5 m ³ /h	2" and 1.5"	2": 50 mm	910 W	600 W	2.6/1.5 A	20	SP2611HY163	IE3 ✓
1.5 HP	254 mm	15.5 kg	18 m ³ /h	2"	2": 63 mm	1060 W	750 W	2.85/1.65 A	20	SP2616HY223	IE3 ✓
2 HP	254 mm	17.5 kg	22.4 m ³ /h	2"	2": 63 mm	1310 W	1100 W	4.0/2.3 A	20	SP2622HY253	IE3 ✓

* under 8 m water column pressure