

TriStar®



UNRIVALLED HYDRAULIC PERFORMANCE

- A modern, optimised design **for optimum hydraulic efficiency**
- **Higher delivery rate for lower energy consumption**
- **Proven reliability and durability** thanks to the polypropylene fiberglass reinforced wet end
- **Easy maintenance:** twist-lock cover + extra wide strainer basket for less frequent cleaning
- Recommended for pools **up to 195 m³***

* Calculation based on 6 hours turnover



Easy-to-service design provides simple installation and maintenance

Drain plugs for an easy wintering

See-through strainer cover

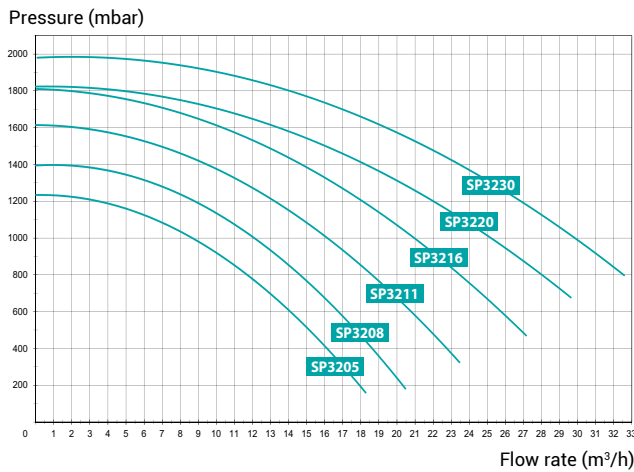
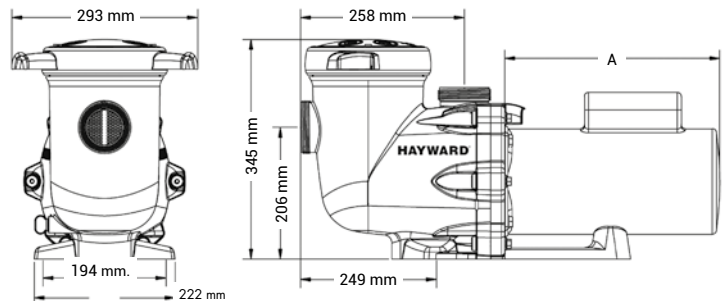

THIS PUMP MODEL EXISTS IN VARIABLE SPEED

Technical Specifications

Max. water temp.	35°C
Mechanical seal	AISI 316, compatible with salt treatment (salt chlorinator)
Motor specifications	Class F, IP55, 50 Hz, 2 Poles
Housing/impeller/strainer/lid	PP+GF/Noryl® + GF/ABS/PC
Prefilter size	4.5 L

	Type	Dim A	Weight	Fitting*	Flow rate*	Input Power P1	Output Power P2	Amperage	Quantity per pallet	Item
SINGLE PHASE TRISTAR®	1/2 HP	220 mm	14 kg	63 mm	11.4 m³/h	660 W	430 W	2.8 A	10	SP32051
	3/4 HP	220 mm	14 kg	63 mm	14.5 m³/h	800 W	430 W	3.4 A	10	SP32081
	1 HP	247 mm	14 kg	63 mm	18.5 m³/h	1000 W	720 W	4.3 A	10	SP32111
	1.5 HP	247 mm	15 kg	63 mm	23.5 m³/h	1350 W	790 W	5 A	10	SP32161
	2 HP	265 mm	17 kg	63 mm	28 m³/h	1650 W	1160 W	7.25 A	10	SP32201
	3 HP	316 mm	17 kg	63 mm	32.5 m³/h	2100 W	1680 W	9 A	10	SP32301
THREE PHASE TRISTAR®	2 HP	247 mm	15 kg	63 mm	28 m³/h	1600 W	1100 W	4/2.3 A	10	SP32203
	3 HP	265 mm	17 kg	63 mm	32.5 m³/h	2000 W	1500 W	5.5/3.2 A	10	SP32303

* under 8 m water column pressure